

FAG SNV100-F-L + 1211 + DHV211参数

说明		SNV100-F-L		型号, 轴承座
重量	m_1	4300	g	质量, 轴承座
说明		1211		型号, 轴承
		KM11		型号, 锁紧螺母
		MB11		型号, 爪式垫圈
		FRM100/11.5		型号, 定位圈
		DHV211		型号, V 型密封
		DKV100		型号, 端盖
尺寸	d	55	mm	-
	a	255	mm	-
	h_1	133	mm	-
	g	105	mm	-
	b	70	mm	-
	c	28	mm	-
	D	100	mm	-
	d_2	65	mm	-
	g_3	12.5	mm	-
	g_V	111	mm	-
	h	70	mm	-
	m	210	mm	-
	s	M16		-
	s	15.875	mm	-
	u	18	mm	-
	v	23	mm	-

FAG SNV100-F-L + 1211 + DHV211图片

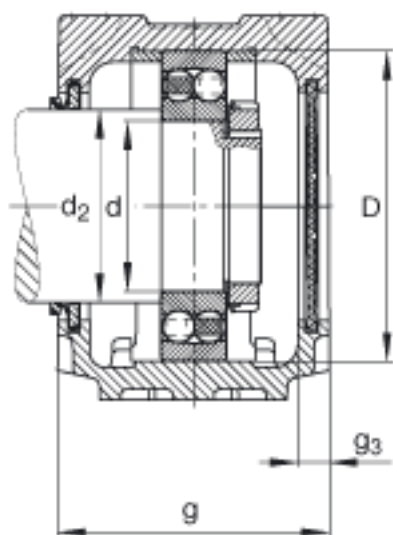

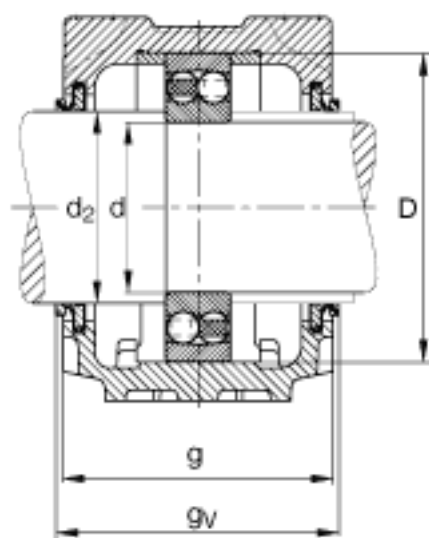
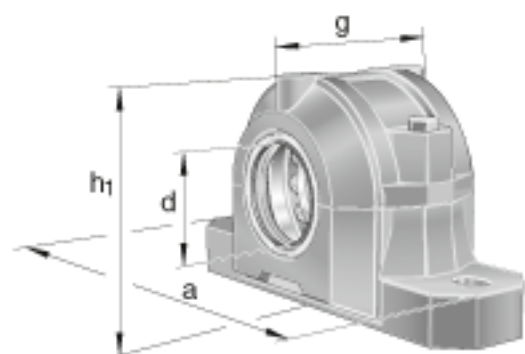

参考资料:<http://www.sozhou.com/p/4c64c2c8.html>